

Homework # 10 Solutions

set of units used: MKSA

-Problem 1- A spherical shell of charge undergoes purely radial oscillations. Show that no radiation is emitted. (This is H&M, problem 9-2).

SOLUTION

We will give two solutions of the problem: a long one (i.) and a short one (ii.)

- i. Consider the limit case in which the distribution of the source currents generated by the shell oscillations ($\mathbf{J}(\mathbf{r}', t)$), is confined into a region very small with respect to its distance from the point of observation, namely ¹

$$d \ll r \quad , \quad (1)$$

where d is of the order of magnitude of the dimension of the source and $r \equiv |\mathbf{x} - \mathbf{x}'|$ is the distance between the source, at \mathbf{x}' and the point at which we measure the fields \mathbf{x} . In this limit the following relation holds

$$|\mathbf{x} - \mathbf{x}'| \simeq x - \mathbf{x}' \cdot \left(\frac{\mathbf{x}}{x} \right) \quad , \quad (2)$$

so that

$$\frac{1}{r} \simeq \frac{1}{x} \left(1 + \frac{\mathbf{x} \cdot \mathbf{x}'}{x^2} \right) \quad . \quad (3)$$

The general solution for the vector potential generated by a localized oscillating source is

$$\mathbf{A}(\mathbf{x}, t) = \frac{\mu_o}{4\pi} \int \frac{\mathbf{J}(\mathbf{x}', t - r/c)}{r} d\mathbf{x}' \quad . \quad (4)$$

¹This limit case is a good approximation either for the so called **radiation zone**, defined by $d \ll \lambda \ll r$, or for the **static zone**, defined by $d \ll r \ll \lambda$.

Assuming a sinusoidal time dependence of the current density, $\mathbf{J}(\mathbf{r}', t) = \mathbf{J}(\mathbf{r}') \exp(-i\omega t)$ and using approximation (3) we get

$$\mathbf{A}(\mathbf{x}, t) = \frac{\mu_o e^{-i\omega(t-x/c)}}{4\pi x} \int \mathbf{J}(\mathbf{x}') e^{-ikr'\hat{\mathbf{r}}} d\mathbf{x}' \quad , \quad (5)$$

where $k = \omega/c$ and we kept only the dominant term in kx . Since for the spherical shell with oscillating radius we have $\mathbf{J}(\mathbf{r}', t) \propto \mathbf{r}'$ then from eq. (5) we get

$$\mathbf{A}(x[\gg d, \lambda], t) \propto \int \mathbf{r}' f(\mathbf{r}' \cdot \mathbf{r}) d\mathbf{r}' = 0 \quad . \quad (6)$$

where f is a certain function. Then a spherical shell of constant total charge whose radius scillates does not radiate.

- ii. From the radiation zone the Electric field of the spherical shell whose radius oscillates is indistinguishable from the one of a point charge of constant charge Q ² (the total charge on the shell is infact constant). This means that the electric field due to the oscillating shell is a static field: it coincides with the one of an electric *monopole* with constant charge. Then it does not radiate³

²According to Gauss' s law the field outside is exactly $Q\hat{\mathbf{r}}/(4\pi\epsilon_o r^2)$, regardless of the fluctuations in size.

³In the acoustic analog, by the way, monopoles radiate: witness the croak of a bullfrog

-Problem 2- A piece of wire bent into a loop, as shown in figure 1, carries a current that increases linearly with time:

$$I(t) = \alpha t \quad . \quad (1)$$

Calculate the retarded vector potential \mathbf{A} at the center. Find the electric field at the center. Why does this (neutral) wire produces an *electric field*? (Why can't you determine the *magnetic field* from this expression for \mathbf{A} ?)

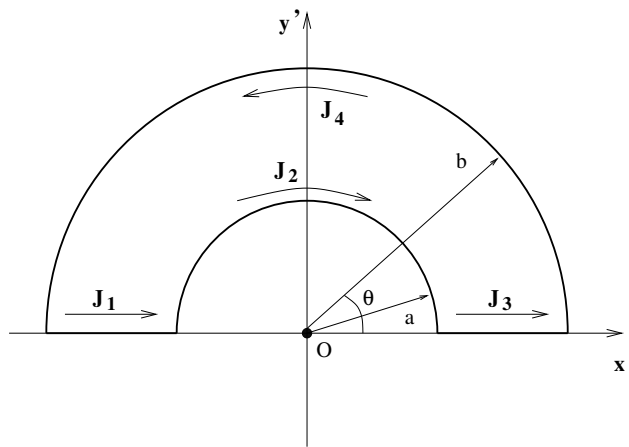

Figure 1: Neutral wire bent in a loop and carrying current $I(t) = \alpha t$.

SOLUTION

Since the wire is electrically neutral the scalar potential is zero. The retarded vector potential at the center is given by

$$\mathbf{A}(O, t) = \mathbf{A}_1(O, t) + \mathbf{A}_2(O, t) + \mathbf{A}_3(O, t) + \mathbf{A}_4(O, t) \quad , \quad (2)$$

where \mathbf{A}_i are the vector potential due to the i -th piece of wire (see figure 1), namely

$$\mathbf{A}_i(\mathbf{x}, t) = \frac{\mu_0}{4\pi} \int \frac{\mathbf{J}_i(\mathbf{x}', t - r/c)}{r} d\mathbf{x}' \quad , \quad (3)$$

where $r = |\mathbf{x} - \mathbf{x}'|$ and $\mathbf{J}_i(\mathbf{x}', t - r/c)$ is the current density in the i -th piece of wire calculated at the retarded time. In the problem we have to calculate

the vector potential at $\mathbf{x} = O$ then $r = x'$. For the various pieces of wire (see figure 1) we have

$$\mathbf{J}_1(\mathbf{x}', t - r/c) = \hat{\mathbf{x}}' \delta(z') \delta(y') \theta(-x' - a) \theta(x' + b) \alpha(t - r/c) , \quad (4)$$

$$\mathbf{J}_3(\mathbf{x}', t - r/c) = \hat{\mathbf{x}}' \mathbf{J}_1(-\mathbf{x}', t - r/c) , \quad (5)$$

$$\mathbf{J}_2(\mathbf{x}', t - r/c) = (\hat{\mathbf{x}}' \sin \theta - \hat{\mathbf{y}}' \cos \theta) \delta(z') \delta(r - a) \alpha(t - r/c) , \quad (6)$$

$$\mathbf{J}_4(\mathbf{x}', t - r/c) = -(\hat{\mathbf{x}}' \sin \theta + \hat{\mathbf{y}}' \cos \theta) \delta(z') \delta(r - b) \alpha(t - r/c) , \quad (7)$$

where $\theta(x)$ is the Heaviside step-function defined as $\theta(x) = 1$ for $x > 0$ and $\theta(x) = 0$ otherwise. Inserting these expressions into eq (3) we get

$$\mathbf{A}_1 = \mathbf{A}_3 = \hat{\mathbf{x}}' \frac{\alpha \mu_o}{4\pi} \int_a^b \frac{t - x/c}{x} dx \quad (8)$$

$$= \hat{\mathbf{x}}' \left(\frac{\alpha \mu_o}{4\pi} t \ln \left(\frac{b}{a} \right) - \frac{\alpha \mu_o}{4\pi c} (b - a) \right) , \quad (9)$$

$$\mathbf{A}_2 = \hat{\mathbf{x}}' \frac{\mu_o}{4\pi} \int_0^\pi \frac{t - a/c}{a} \sin \theta \, a d\theta = \hat{\mathbf{x}}' \frac{\mu_o}{2\pi} (t - a/c) , \quad (10)$$

$$\mathbf{A}_4 = -\hat{\mathbf{x}}' \frac{\mu_o}{4\pi} \int_0^\pi \frac{t - b/c}{b} \sin \theta \, b d\theta = -\hat{\mathbf{x}}' \frac{\mu_o}{2\pi} (t - b/c) . \quad (11)$$

We can finally collect all these results to get \mathbf{A} as

$$\mathbf{A} = (\mathbf{A}_1 + \mathbf{A}_3) + (\mathbf{A}_2 + \mathbf{A}_4) \quad (12)$$

$$= \hat{\mathbf{x}}' \left\{ \frac{\mu_o \alpha}{2\pi} \left[t \ln \left(\frac{b}{a} \right) - \frac{(b - a)}{c} \right] + \frac{\mu_o \alpha t (b - a)}{2\pi c} \right\} \quad (13)$$

$$= \hat{\mathbf{x}}' \frac{\mu_o \alpha t}{2\pi} \ln \left(\frac{b}{a} \right) . \quad (14)$$

We can then find the electric field at the center O as

$$\mathbf{E}(O, t) = -\frac{\partial \mathbf{A}(O, t)}{\partial t} = -\hat{\mathbf{x}}' \frac{\mu_o \alpha}{2\pi} \ln \left(\frac{b}{a} \right) . \quad (15)$$

The neutral wire produces an electric field because it contains accelerated charges. We cannot determine the magnetic field from the expression (12) for \mathbf{A} because we have only calculated \mathbf{A} at one point in space.

-Problem 3- Find the **radiation resistance** of the wire joining the two ends of a dipole. (This is the resistance that would give the same average power loss - to heat - as the oscillating dipole in fact puts out in the form of radiation.) Show that $R = 790(s/\lambda)^2\Omega$, where λ is the wavelength of the radiation. For the wires in ordinary radio (say, $s = 5cm$), should you worry about the radiative contribution to the total resistance?

SOLUTION

Imagine two tiny metal spheres separated by a distance s and connected by a fine wire. Assume the system as a whole is electrically neutral, so if at time t the charge on one sphere is $q(t)$, then the charge on the other sphere is $-q(t)$. Suppose further that we somehow contrive to drive the charge back and forth through the wire, from one end to the other, at a frequency ω

$$q(t) = q_o \cos \omega t \quad . \quad (1)$$

This is a simple model for an oscillating electric dipole

$$\mathbf{p}(t) = q(t)\mathbf{s} \quad , \quad (2)$$

where \mathbf{s} is the vector connecting the two spheres. The average power radiated from the dipole is

$$\langle P \rangle = \frac{1}{4\pi\epsilon_o} \frac{p_o^2\omega^4}{3c^3} \quad , \quad (3)$$

where ω is the frequency of the radiation and $p_o = sq_o$ is the maximum value of the dipole moment.

The average power dissipated in heat (by Joule effect) into the wire joining the two spheres is

$$\langle P \rangle = R\langle I^2 \rangle \quad , \quad (4)$$

where

$$\langle I^2 \rangle = \langle \dot{q}^2(t) \rangle = \langle q_o^2\omega^2 \sin^2(\omega t) \rangle \quad (5)$$

$$= \frac{p_o^2\omega^2}{s^2} \langle \sin^2\omega t \rangle = \frac{p_o^2\omega^2}{2s^2} \quad . \quad (6)$$

Equating eqs. (3) and (4) as suggested by the problem and using the relation $\omega = 2\pi c/\lambda$ we find the radiation resistance as

$$R = \left[\frac{1}{4\pi\epsilon_o} \frac{p_o^2 \omega^4}{3c^3} \right] \left[\frac{p_o^2 \omega^2}{2s^2} \right]^{-1} = \frac{2\pi}{3c\epsilon_o} \left(\frac{s}{\lambda} \right)^2 \quad (7)$$

$$\sim 790\Omega \left(\frac{s}{\lambda} \right)^2 . \quad (8)$$

In ordinary radio $s \sim 5cm$. Short radio waves: $10^{-1}cm - 10^2m$, radio broadcast: $10^2m - 10^4m$. Taking a wavelength of $10^3m \gg s$ (we want to be as close as possible to the condition of *perfect dipole*) we get

$$R \sim 2 \times 10^{-6}\Omega . \quad (9)$$

then we shouldn't worry about the radiative contribution to the total resistance.

-Problem 4- As you know, the magnetic north pole of the earth does not coincide with the geographic north pole - in fact, it's off by about 11° . Relative to the fixed axis of rotation, therefore, the magnetic dipole moment vector of the earth is changing with time, and the earth must be giving off magnetic dipole radiation.

- (a) Find the formula for the total power radiated, in terms of the following parameters

Ψ (the angle between the geographic and magnetic north poles) ,
 M (the magnitude of the earth's magnetic dipole moment) ,
 ω (the angular velocity of rotation of the earth) .

- (b) Using the fact that the earth's magnetic field is about $1/2\text{gauss}$ at the equator, estimate the magnetic dipole moment M of the earth.
- (c) Find the power radiated in watts
- (d) Pulsars are thought to be rotating neutron stars, with a typical radius of 10km , a rotational period of 10^{-3}s , and a surface magnetic field of 10^8T . What sort of radiated power would you expect from such a star? (See J. P. Ostriker and J. E. Gunn, *Astrophys. J.*, **157**, 1395 (1969).)

SOLUTION

- (a) The formula for the total power radiated by the earth is

$$\langle P \rangle = -2 \frac{1}{4\pi\epsilon_0} \frac{m_\perp^2 \omega^4}{3c^5} , \quad (1)$$

where $m_\perp = M \sin \Psi$ is the components of the magnetic-dipole moment perpendicular to the rotation axes. The factor of two can be explained with the following superposition argument. When we project the magnetic-dipole moment M of the earth on the rotation axis and on other two perpendicular axis on the equatorial plane, the component along the rotation axis is constant with time and doesn't contribute to the radiation, while the other *two* components constitutes oscillating magnetic-dipole moment with an amplitude given by $M \sin \Psi$.

- (b) Taking the $\hat{\mathbf{z}}$ axes coincident with the direction of the magnetic-dipole moment of the earth we have for the magnetic field at an angle θ

$$\mathbf{B} = \frac{\mu_o}{4\pi} \frac{M}{R^3} (2 \cos \theta \hat{\mathbf{r}} + \sin \theta \hat{\theta}) . \quad (2)$$

At the equator $\theta_o \sim 90^\circ - 11^\circ = 79^\circ$. Knowing that the earth's magnetic field is about $B_{eq} \sim 0.5 \text{ gauss} = 5 \times 10^{-5} T$ at the equator we can then estimate the magnetic-dipole moment M of the earth as

$$M = \frac{B_{eq} 4\pi R^3}{\mu_o \sqrt{4 \cos^2 \theta_o + \sin^2 \theta_o}} \sim 1.23 \times 10^{23} \text{ Am}^2 \quad (3)$$

where we used $R \sim 6.37 \times 10^6 m$ and $\mu_o \sim 4\pi 10^{-7} N/A^2$.

- (c) From eq. (1) and using $\epsilon_o = 8.85 \times 10^{-12} \text{ coul}^2/Nm^2$ and $c = 3 \times 10^8 m/s$ we get

$$\langle P \rangle \sim 4 \times 10^{-5} W . \quad (4)$$

- (d) Using again eq. (1) but this time using $B \sim 10^8 T$, $R \sim 10^4 m$ and $\omega \sim 2\pi/10^{-3} \text{ rad/s} \sim 6.3 \times 10^3 \text{ rad/s}$ we get

$$\langle P \rangle \sim 2 \times 10^{36} W . \quad (5)$$